

4

3

2

1

D

D

C

C

B

B

A

A

REVISIONS

ZONE	REV	DESCRIPTION	DATE	APPROVED

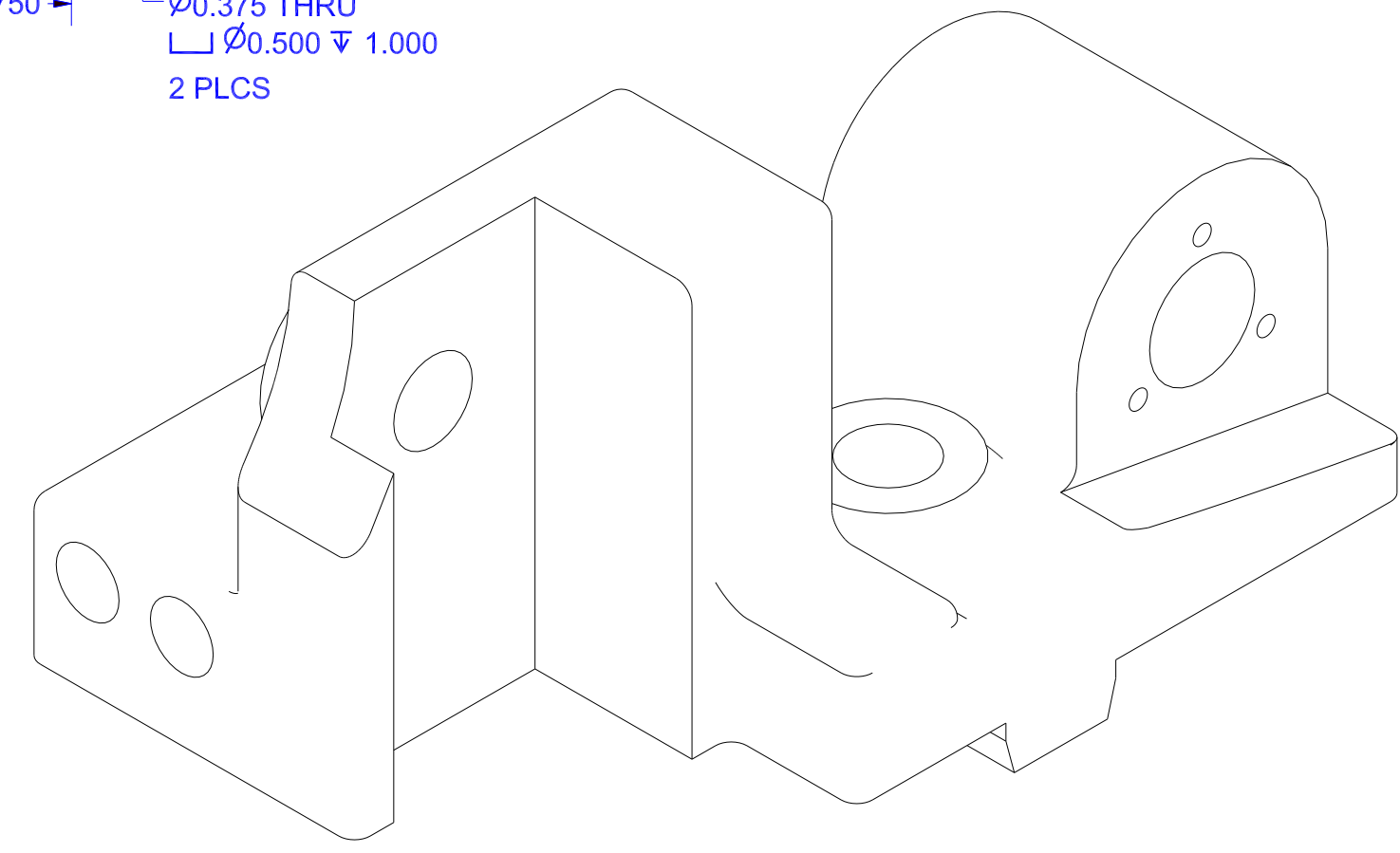
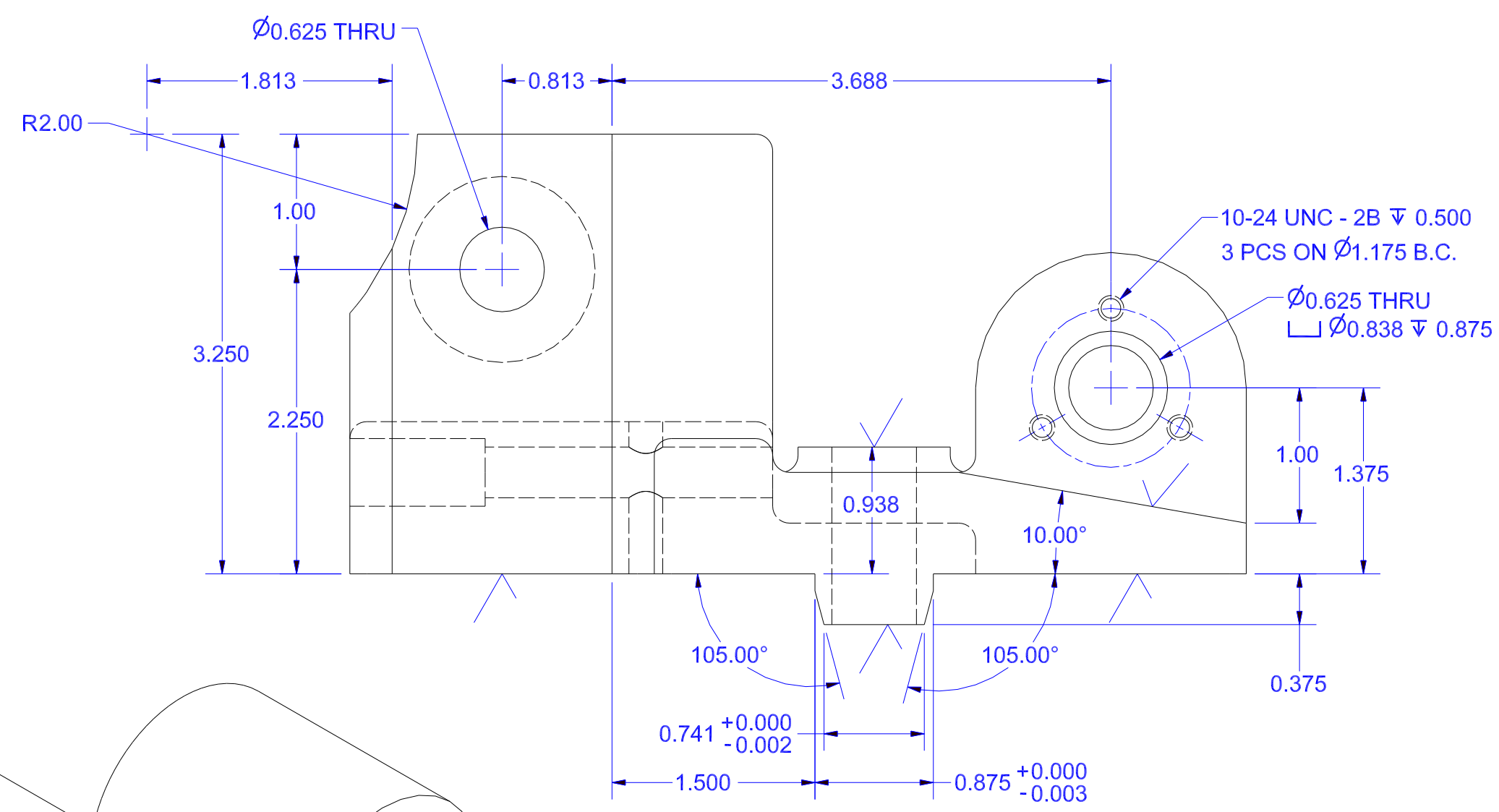
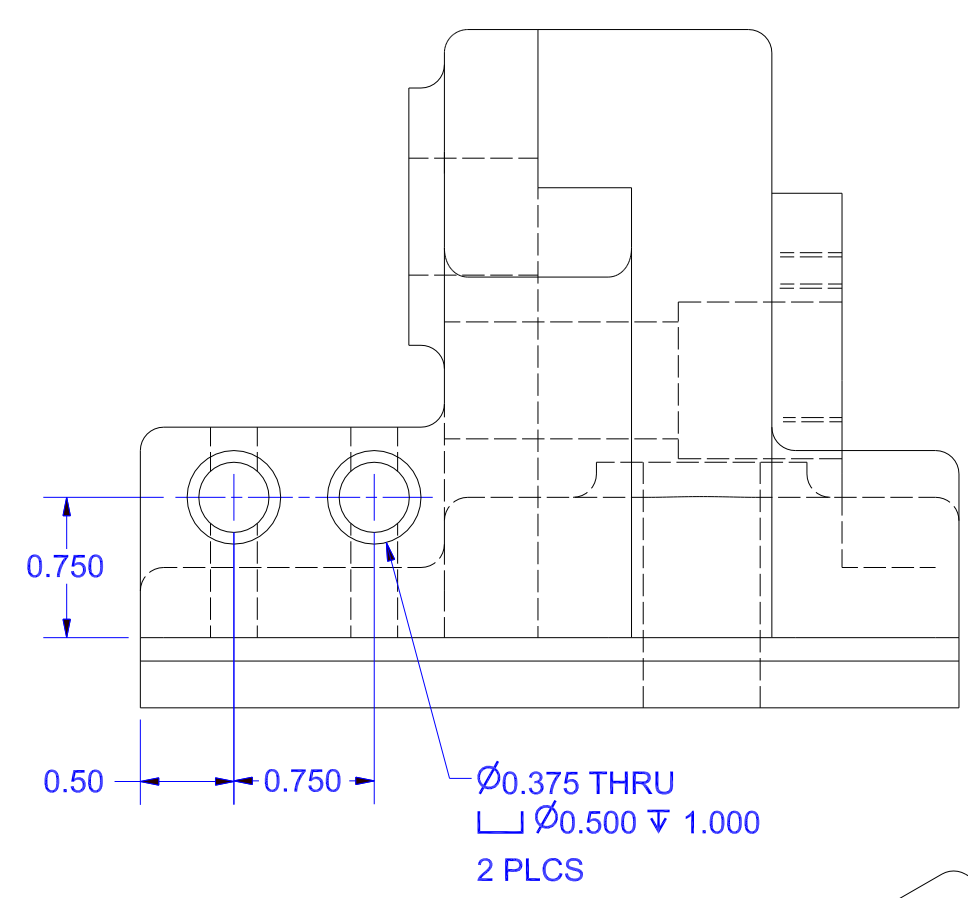
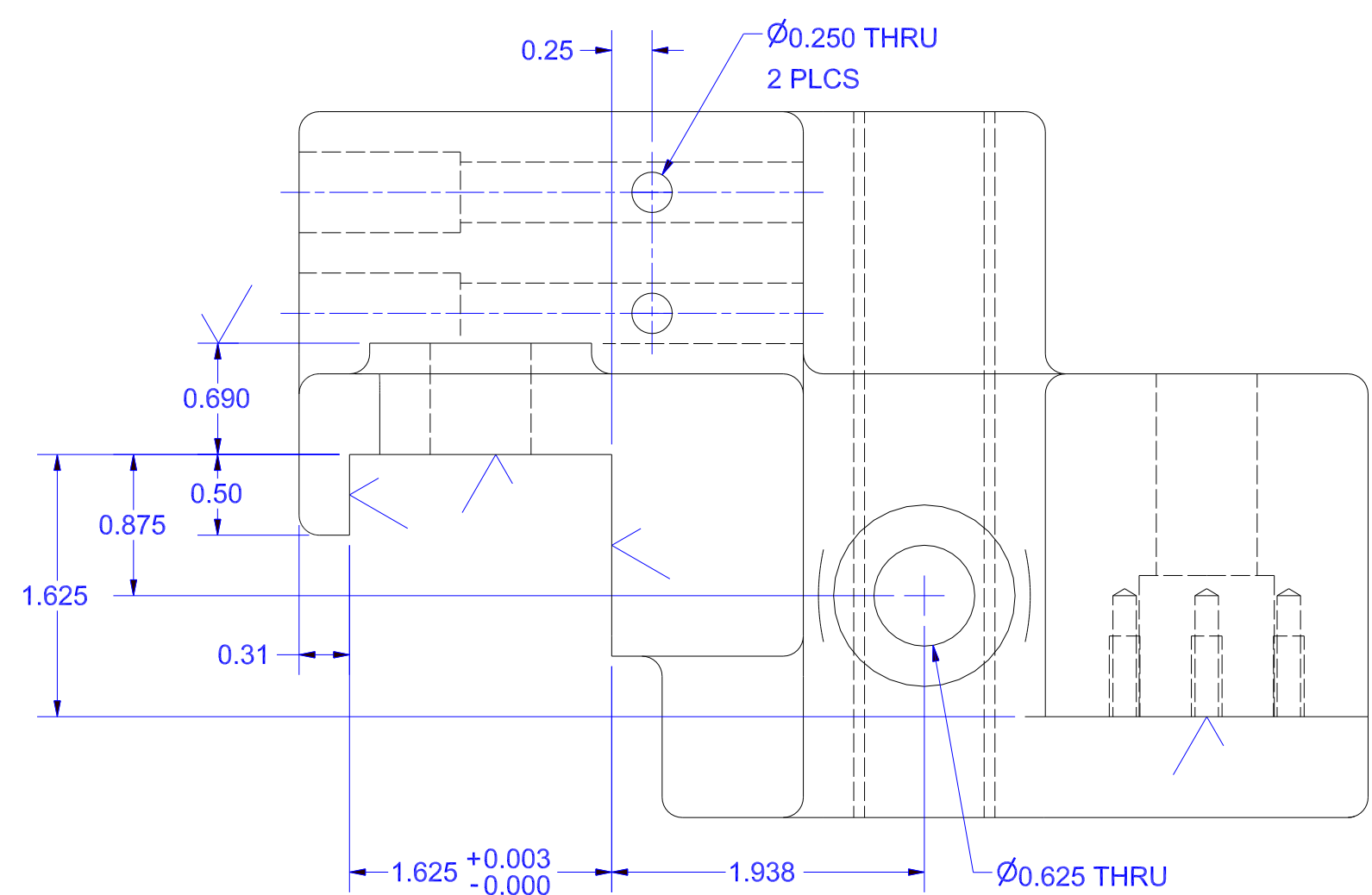

NOTES:

1. STANDARD PRACTICE SPEC XX-XXX-XXXX

**MATERIAL: CASTING XXX-XX-XXXX**

UNLESS OTHERWISE NOTED TOLERANCES ARE: X/X $\pm \frac{1}{32}$ .X $\pm .03$ .XX $\pm .015$ .XXX $\pm .005$ ANGULAR $\pm 1^\circ$	125 ✓		XXXX XXXXX - XXXX XXXXXX XXXXXXXX XXXX	
	XXXX XXX XX XXXXXX	SIZE C	ECO NO. XXXX-X	DWG NO. XX-XXXX
XXXXXXXXXX	SCALE FULL	SHEET 1 of 1		

4

3

2

1